

# MP-1500P-60

## General Features

- Engine (PERKINS 4012-46TWG3A), Radiator 50°C max, belt driven fans, with safety guard
- 24V charge alternator
- Alternator (Stamford, Leroy Somer & Mecc Alte for option), single bearing alternator IP23, insulation class H/H
- Skid and vibration isolators
- Dry type air filter, fuel filter, oil filter
- Main line circuit breaker
- Permanent Magnet Generator (PMG)
- Standard control panel
- Four 12V batteries, rack and cable
- Ripple flex exhaust pipe, exhaust siphon, flange, industrial muffler

PHOTO FOR REFERENCE ONLY



## Technical Data

Output Frequency	60 Hz
Rated Speed	1800RPM
Prime Power	1364KVA/1090KW
Standby Power	1500KVA/1200KW
Rated Voltage	440/254V
Phase	3
Power Factor	0.8
Fuel Consumption 100% Load	289L/Hr
Fuel Consumption 75% Load	TBAL/Hr
Fuel Consumption 50% Load	TBAL/Hr
Operation Altitude	≤1000m
Ambient Temperature	≤50°C

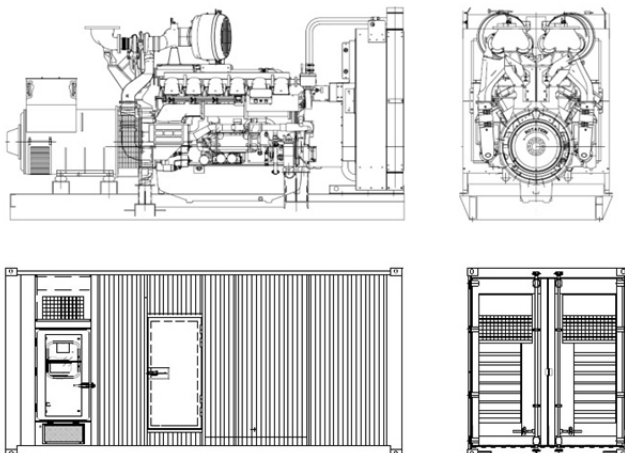

## Dimension and Weight

Genset Type	Open Frame	Soundproof ISO 20ft GP
Length(L) (mm)	4800	6058
Width(W) (mm)	2000	2438
Height(H) (mm)	2700	2591
Gross Weight (kg)	TBA	TBA

## MP-1500P-60

### Engine Specification

Manufacturer / Model:	PERKINS 4012-46TWG3A, 4-cycle
Air Intake System:	Turbocharged, Air/Water Cooling
Fuel System:	Direct
Cylinder Arrangement:	12 in V
Displacement:	45.842L
Bore and Stroke:	160*190 (mm)
Compression Ratio:	13:1
Rated RPM:	1800rpm
Max. Standby Power at Rated RPM:	1314KW
Governor Type:	Electronic
Combustion air flow:	116m <sup>3</sup> /min
Cooling fan air flow:	1600m <sup>3</sup> /min
Exhaust Gas Flow:	250m <sup>3</sup> /min
Exhaust Temperature:	478°C
Max Back Pressure:	5kPa
Max Intake Restriction:	4kPa
Total Oil Capacity:	177L
Oil Consumption:	0.7g/KWh
Total Coolant Capacity – Engine Only:	73L
Thermostat:	71-85°C
Max Water Temperature:	101°C

### Alternator Specification

Manufacturer / Model:	STAMFORD S6L1D-G4
Number of Phase:	3
Connecting Type:	3 Phase and 4 Wires, "Y" type connecting
Number of Bearing:	1
Protection Grade:	IP23
Exciter Type:	Brushless, self-exciting
Insulation Class, Temperature Rise:	H/H
TIF:	< 50
THF:	< 2%
Voltage Regulation, Steady State:	≤ ± 1%
Alternator Capacity:	1431KVA
Alternator Efficiencies:	94.9%
Air Cooling Flow:	2.34m <sup>3</sup> /s

**MP-1500P-60**

**Control System**

**Standard Deepsea DSE6020 Auto Mains Failure Control Panel**

- Manual or Auto Start Module for single genset applications. Designed to work with electronic and non-electronic engines, providing advanced engine monitoring and protection features.
- Includes a back-lit icon LCD display which shows the status of the engine at all times. Monitors engine speed, frequency, voltage and run hours and also displays the warning and shutdown status.
- Includes extensive outputs and inputs making this product ideal for a wide variety of applications. It can either be programmed using the front panel or by using DSE PC software.



**Optional Deepsea DSE7320 Auto Mains Failure Control Panel**

- Auto Mains (Utility) Failure Control Module suitable for a wide variety of single genset applications.
- Displays warnings, shutdown and engine status info on the back-lit LCD screen, illuminated LEDs, remote PC. Monitors the mains (utility) supply. Includes USB, RS232 and RS485 ports for system expansion.
- Compatible with electronic and non-electronic engines and offer flexible inputs, outputs and engine protections to meet extensive industry requirements.
- Includes enhanced event and performance monitoring, remote communications to reduce engine wear. It can either be programmed using the front panel or by using DSE PC software.



**Optional Deepsea DSE8610 Auto Paralleling Control Panel**

- Synchronizing Auto Start Control Module for multi-genset load share system, designed to synchronize up to 32 gensets including electronic and non-electronic engines.
- Monitors the genset and indicates operational status and fault conditions, automatically starting or stopping the engine on load demand or fault condition.
- System alarms are annunciated on the LCD screen, illuminated LED and audible sounder.
- Records 250 events log for maintenance. Extensive monitoring, metering and protection features are included as well as comprehensive communication and system expansion options.
- Using DSE PC Software allows alteration of the operational sequences, timers, alarms with all communication ports active.



**MP-1500P-60****Options****Engine**

- Water Jacket Preheater
- Water Separator
- Oil Pump
- Oil Preheater
- Battery Charger

**Fuel System**

- Daily Fuel Tank
- External Fuel Tank
- Auto Fuel Filling System
- Fuel Level Sensor

**Control System**

- Auto Remote Control Panel
- AMF Function Control Panel
- Auto Paralleling Control Panel
- Auto Transfer Switch (ATS)
- ABB breaker

**Alternator**

- Anti Condensation Heater
- Winding Temp Sensor

**Available Voltages**

- 380V,400V,460V,480V(L-L)

**Reference Standards**

**Generator Set:** ISO 8528, CE

**Engine:** ISO 3046, BS 5514, DIN 6271

**Alternator:** BS EN 60034, IEC34, BS5000, NEMA MG1-32, VDE 0530, CSA C22.2-100, AS1359

**Warranty**

Mega Power provides a full line of brand new and high quality products. Each and every unit is strictly factory tested.

Warranty is according to our standard conditions: A. 15 months, counted on the day Mega sold to the first buyer; B. One year after installation; C. 1000 running hours (accumulated); subject to the earlier one.

Service and spare parts are available from Mega Power or distributors in your location.