

MP-17P-60

General Features

- Engine (PERKINS 403D-15G), Radiator 50°C max, belt driven fans, with safety guard
- 24V charge alternator
- Alternator (Stamford, Leroy Somer & Mecc Alte for option), single bearing alternator IP23, insulation class H/H
- Skid and vibration isolators
- Dry type air filter, fuel filter, oil filter
- Main line circuit breaker
- Standard control panel
- Two 12V batteries, rack and cable
- Ripple flex exhaust pipe, exhaust siphon, flange, industrial muffler

PHOTO FOR REFERENCE ONLY



Technical Data

Output Frequency	60 Hz
Rated Speed	1800RPM
Prime Power	16KVA/12.8KW
Standby Power	17KVA/13.6KW
Rated Voltage	440/254V
Phase	3
Power Factor	0.8
Fuel Consumption 100% Load	4.4L/Hr
Fuel Consumption 75% Load	3.4L/Hr
Fuel Consumption 50% Load	2.5L/Hr
Operation Altitude	≤1000m
Ambient Temperature	≤50°C

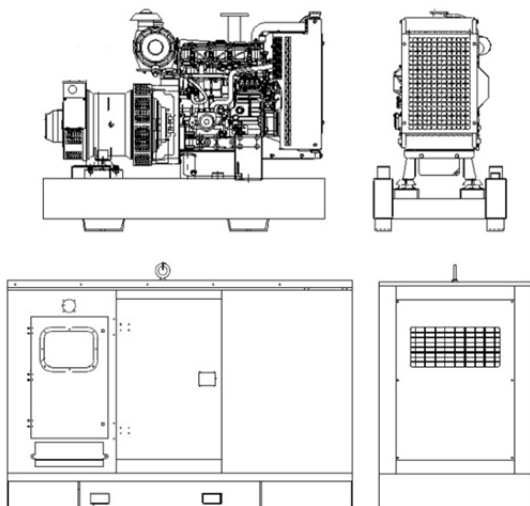

Dimension and Weight

Genset Type	Open Frame	Soundproof
Length(L) (mm)	1250	1700
Width(W) (mm)	500	910
Height(H) (mm)	1100	1450
Gross Weight (kg)	370	770

MP-17P-60**Engine Specification**

Manufacturer / Model:	PERKINS 403D-15G, 4-cycle
Air Intake System:	Natural
Fuel System:	Direct
Cylinder Arrangement:	3 in line
Displacement:	1.496L
Bore and Stroke:	84*90 (mm)
Compression Ratio:	22.5:1
Rated RPM:	1800rpm
Max. Standby Power at Rated RPM:	16.2KW
Governor Type:	Mechanical
Combustion air flow:	1.23m ³ /min
Cooling fan air flow:	45.4L/min
Exhaust Gas Flow:	3.36m ³ /min
Exhaust Temperature:	505°C
Max Back Pressure:	10.2kPa
Max Intake Restriction:	6.4kPa
Total Oil Capacity:	6L
Oil Consumption:	0.15% fuel consumption
Total Coolant Capacity:	6L
Thermostat:	82-95°C
Max Water Temperature:	112°C

Alternator Specification

Manufacturer / Model:	STAMFORD S0L1-P1
Number of Phase:	3
Connecting Type:	3 Phase and 4 Wires, "Y" type connecting
Number of Bearing:	1
Protection Grade:	IP23
Exciter Type:	Brushless, self-exciting
Insulation Class, Temperature Rise:	H/H
TIF:	< 50
THF:	< 2%
Voltage Regulation, Steady State:	≤ ± 1%
Alternator Capacity:	16.8KVA
Alternator Efficiencies:	84.0%
Air Cooling Flow:	0.07m ³ /s

MP-17P-60

Control System

Standard Deepsea DSE6020 Auto Mains Failure Control Panel

- Manual or Auto Start Module for single genset applications. Designed to work with electronic and non-electronic engines, providing advanced engine monitoring and protection features.
- Includes a back-lit icon LCD display which shows the status of the engine at all times. Monitors engine speed, frequency, voltage and run hours and also displays the warning and shutdown status.
- Includes extensive outputs and inputs making this product ideal for a wide variety of applications. It can either be programmed using the front panel or by using DSE PC software.



Optional Deepsea DSE7320 Auto Mains Failure Control Panel

- Auto Mains (Utility) Failure Control Module suitable for a wide variety of single genset applications.
- Displays warnings, shutdown and engine status info on the back-lit LCD screen, illuminated LEDs, remote PC. Monitors the mains (utility) supply. Includes USB, RS232 and RS485 ports for system expansion.
- Compatible with electronic and non-electronic engines and offer flexible inputs, outputs and engine protections to meet extensive industry requirements.
- Includes enhanced event and performance monitoring, remote communications to reduce engine wear. It can either be programmed using the front panel or by using DSE PC software.



Optional Deepsea DSE8610 Auto Paralleling Control Panel

- Synchronizing Auto Start Control Module for multi-genset load share system, designed to synchronize up to 32 gensets including electronic and non-electronic engines.
- Monitors the genset and indicates operational status and fault conditions, automatically starting or stopping the engine on load demand or fault condition.
- System alarms are annunciated on the LCD screen, illuminated LED and audible sounder.
- Records 250 events log for maintenance. Extensive monitoring, metering and protection features are included as well as comprehensive communication and system expansion options.
- Using DSE PC Software allows alteration of the operational sequences, timers, alarms with all communication ports active.



MP-17P-60**Options****Engine**

- Water Jacket Preheater
- Water Separator
- Oil Pump
- Oil Preheater
- Battery Charger

Fuel System

- Daily Fuel Tank
- External Fuel Tank
- Auto Fuel Filling System
- Fuel Level Sensor

Control System

- Auto Remote Control Panel
- AMF Function Control Panel
- Auto Paralleling Control Panel
- Auto Transfer Switch (ATS)
- ABB breaker

Alternator

- Anti Condensation Heater
- Permanent Magnet Generator
- Winding Temp Sensor

Enclosure

- Rainproof Type
- Soundproof Rental Type
- Mobile Type

Available Voltages

- 380V,400V,460V,480V(L-L)
- 208V,220V,230V,240V(L-L)

Reference Standards

Generator Set: ISO 8528, CE

Engine: ISO 3046, BS 5514, DIN 6271

Alternator: BS EN 60034, IEC34, BS5000, NEMA MG1-32, VDE 0530, CSA C22.2-100, AS1359

Warranty

Mega Power provides a full line of brand new and high quality products. Each and every unit is strictly factory tested.

Warranty is according to our standard conditions: A. 15 months, counted on the day Mega sold to the first buyer; B. One year after installation; C. 1000 running hours (accumulated); subject to the earlier one.

Service and spare parts are available from Mega Power or distributors in your location.